

**CONTRACT DOCUMENTS
FOR:**

2021 ROTHFUSS PARK SPORTS FIELD PROJECT

**FOR THE
TOWN OF PENFIELD**

**BIDS DUE:
MAY 21, 2021
11:00 AM PREVAILING TIME**

**TOWN OF PENFIELD
3100 ATLANTIC AVENUE
PENFIELD, NEW YORK 14526**

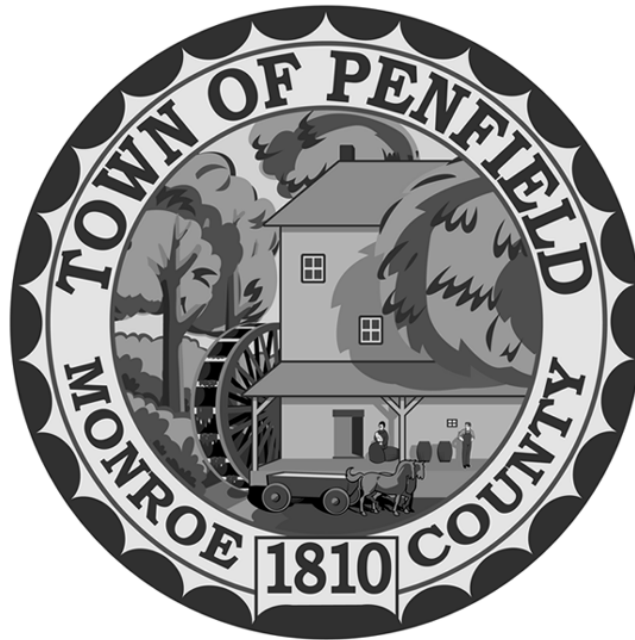

This project is an exempt capital improvement project, and therefore, all federal regulations governing contracts apply, including Labor Standards Provisions and Davis-Bacon Wage Rates, Equal Employment Opportunity requirements and Section # Provisions.

ROTHFUSS PARK SPORTS FIELD PROJECT
TOWN OF PENFIELD, MONROE COUNTY, NEW YORK

TABLE OF CONTENTS

Notice to Bidders	3
Instruction to bidders	5
Specifications/ Details	13
Bid Sheet	18
Bid Proposal Requirements	21
Mapping	23

NOTICE TO BIDDERS

NOTICE TO BIDDERS

The Town/Village of **Penfield** invites bids for the **2021 Rothfuss Park sports field project** located at **Town of Penfield Town Hall, 3100 Atlantic Ave,**

In accordance with Section 103 of Article 5-A of General Municipal Law. The bids shall include all labor, equipment, and materials necessary to perform the work as indicated in the Technical Specifications which are part of these Contract Documents.

Sealed bids will be received by the Town/Village of **Penfield** on **May 21 2021**, until **11:00** A.M. at which time and place they will be publicly opened and read aloud.

The scope of work for the project will generally consist of **2021 Rothfuss Park sports field project.**

Specifications and bid documents may be obtained at no charge at the Office of **Town of Penfield, Town Clerk** And examined free of charge at the following locations during normal business hours:

- Town/Village of **Penfield**;
- Builders Exchange, 180 Linden Oaks, Suite 100, Rochester, N.Y. 14625;
- Dodge Report Office, 30 Erie Canal Drive, Rochester, N.Y. 14626; and the

Contract Documents and Specifications may be obtained in person at the following location upon payment of \$ 0 for each set of documents requested:

Duly authorized M/WBE's are exempt from payment of the deposit upon presentation of documented evidence of current approved certification from the State of New York.

Bidders are required to execute certifications as part of the bid proposal, including a non-collusive bid certification pursuant to section 103-d of the General Municipal Law of the Stat of New York.

INSTRUCTION TO BIDDERS

TO ALL PROSPECTIVE BIDDERS:

The Town of Penfield, Monroe County, New York (in accordance with Section 103 of Article 5-A of the General Municipal Law) hereby invites the submission of sealed bids for:

**2021 ROTHFUSS PARK SPORTS FIELD PROJECT
Contract #1: General**

The Work is generally described as:

The project is located at the Town of Penfield Rothfuss Park at 1648 Five Mile Line Road. The project is exclusively on Town property along the south property line as well as the southeast corner of the park. This project includes the grading and shaping of three (3) multi-purpose sports fields including all associated storm sewer and appurtenances, erosion control measures and lawn restoration with 6" to 8" of screened topsoil and seed per the attached specifications, including all labor, material, equipment.

Access to the site is to utilize the existing curb cut at the south property line. Contactor may use the existing asphalt path to gain access to the proposed site. Contractor will be responsible for protecting the general public from the work area and access drive. Contractor will also be responsible for any damage to the existing asphalt walking path and lawn area disturbed by construction.

The Town of Penfield, Monroe County, New York, reserves the right to reject any or all bids, or to waive any informalities, or to make an award to other than the low bidder. It further reserves the right to limit the amount of the award.

Attention of the bidders is particularly directed to the requirements of the conditions of employment to be observed and minimum Wage Rates to be paid under the Contract.

The Town of Penfield does not discriminate on the basis of handicapped status in admission or access to, or treatment or employment in, its programs and activities.

INSTRUCTIONS TO BIDDERS

TABLE OF ARTICLES

ARTICLE 1 - DEFINED TERMS.....	1
ARTICLE 2 - COPIES OF BIDDING DOCUMENTS.....	1
ARTICLE 3 - QUALIFICATIONS OF BIDDERS.....	1
ARTICLE 4 - EXAMINATION OF BIDDING DOCUMENTS, OTHER RELATED DATA, AND SITE	1
ARTICLE 5 - PRE-BID CONFERENCE.....	2
ARTICLE 6 - SITE AND OTHER AREAS.....	2
ARTICLE 7 - INTERPRETATIONS AND ADDENDA.....	2
ARTICLE 8 - BID SECURITY.....	3
ARTICLE 9 - CONTRACT TIMES	3
ARTICLE 10 - LIQUIDATED DAMAGES	3
ARTICLE 11 - SUBSTITUTE AND “OR-EQUAL” ITEMS	3
ARTICLE 12 - SUBCONTRACTORS, SUPPLIERS, AND OTHERS.....	3
ARTICLE 13 - PREPARATION OF BID	4
ARTICLE 14 - BASIS OF BID; COMPARISON OF BIDS	4
ARTICLE 15 - SUBMITTAL OF BID.....	5
ARTICLE 16 - MODIFICATION AND WITHDRAWAL OF BID.....	5
ARTICLE 17 - OPENING OF BIDS	5
ARTICLE 18 - BIDS TO REMAIN SUBJECT TO ACCEPTANCE.....	5
ARTICLE 19 – EVALUATION OF BIDS AND AWARD OF CONTRACT	6
ARTICLE 20 - CONTRACT SECURITY AND INSURANCE	6
ARTICLE 21 - SIGNING OF AGREEMENT	6
ARTICLE 23 - SALES AND USE TAXES	6
ARTICLE 24 – WAGE RATE REQUIREMENTS	6

INSTRUCTIONS TO BIDDERS

ARTICLE 1 - DEFINED TERMS

- 1.01 Terms used in these Instructions to Bidders have the meanings indicated in the General Conditions and Supplementary Conditions. Additional terms used in these Instructions to Bidders have the meanings indicated below:
- A. *Issuing Office*--The office from which the Bidding Documents are to be issued and where the bidding procedures are to be administered.

ARTICLE 2 - COPIES OF BIDDING DOCUMENTS

- 2.01 Complete sets of the Bidding Documents may be obtained from the Issuing Office.
- 2.02 Complete sets of Bidding Documents shall be used in preparing Bids; neither Owner nor Engineer assumes any responsibility for errors or misinterpretations resulting from the use of incomplete sets of Bidding Documents.
- 2.03 Owner and Engineer, in making copies of Bidding Documents available on the above terms, do so only for the purpose of obtaining Bids for the Work and do not confer a license or grant for any other use.

ARTICLE 3 - QUALIFICATIONS OF BIDDERS

- 3.01 To demonstrate Bidder's qualifications to perform the Work, within five days of Owner's request, Bidder shall submit written evidence such as financial data, previous experience, present commitments, and such other data as may be called for below.

ARTICLE 4 - EXAMINATION OF BIDDING DOCUMENTS, OTHER RELATED DATA, AND SITE

- 4.01 *Underground Facilities*
- A. Information and data shown or indicated in the Bidding Documents with respect to existing Underground Facilities at or contiguous to the Site is based upon information and data furnished to Owner and Engineer by owners of such Underground Facilities, including Owner, or others.
- 4.02 On request, Owner will provide Bidder access to the Site to conduct such examinations, investigations, explorations, tests, and studies as Bidder deems necessary for submission of a Bid. Bidder shall fill all holes and clean up and restore the Site to its former condition upon completion of such explorations, investigations, tests, and studies. Bidder shall comply with all applicable Laws and Regulations relative to excavation and utility locates.
- 4.03 It is the responsibility of each Bidder before submitting a Bid to:
- A. Examine and carefully study the Bidding Documents, the other related data identified in the Bidding Documents, and any Addenda;
- B. Visit the Site and become familiar with and satisfy Bidder as to the general, local, and Site conditions that may affect cost, progress, and performance of the Work;
- C. Become familiar with and satisfy Bidder as to all Federal, State, and Local Laws and Regulations that may affect cost, progress, and performance of the Work;

INSTRUCTIONS TO BIDDERS

- D. Obtain and carefully study (or accept consequences of not doing so) all additional or supplementary examinations, investigations, explorations, tests, studies, and data concerning conditions (surface, subsurface, and Underground Facilities) at or contiguous to the Site which may affect cost, progress, or performance of the Work or which relate to any aspect of the means, methods, techniques, sequences, and procedures of construction to be employed by Bidder, including applying any specific means, methods, techniques, sequences, and procedures of construction expressly required by the Bidding Documents, and safety precautions and programs incident thereto;
 - F. Agree at the time of submitting its Bid that no further examinations, investigations, explorations, tests, studies, or data are necessary for the determination of its Bid for performance of the Work at the price(s) bid and within the times and in accordance with the other terms and conditions of the Bidding Documents;
 - G. Become aware of the general nature of the work to be performed by Owner and others at the Site that relates to the Work as indicated in the Bidding Documents;
 - H. Correlate the information known to Bidder, information and observations obtained from visits to the Site, reports and drawings identified in the Bidding Documents, and all additional examinations, investigations, explorations, tests, studies, and data with the Bidding Documents;
 - I. Promptly give Engineer written notice of all conflicts, errors, ambiguities, or discrepancies that Bidder discovers in the Bidding Documents and confirm that the written resolution thereof by Engineer is acceptable to Bidder; and
 - J. Determine that the Bidding Documents are generally sufficient to indicate and convey understanding of all terms and conditions for the performance of the Work.
- 4.04 The submission of a Bid will constitute an incontrovertible representation by Bidder that Bidder has complied with every requirement of this Article 4, that without exception the Bid is premised upon performing and furnishing the Work required by the Bidding Documents and applying any specific means, methods, techniques, sequences, and procedures of construction that may be shown or indicated or expressly required by the Bidding Documents, that Bidder has given Engineer written notice of all conflicts, errors, ambiguities, and discrepancies that Bidder has discovered in the Bidding Documents and the written resolutions thereof by Engineer are acceptable to Bidder, and that the Bidding Documents are generally sufficient to indicate and convey understanding of all terms and conditions for performing and furnishing the Work.

ARTICLE 5 - PRE-BID CONFERENCE

- 5.01 No pre-bid conference is scheduled for this project.

ARTICLE 6 - SITE AND OTHER AREAS

- 6.01 The Site is identified in the Bidding Documents. Lands are owned and maintained by the Town of Penfield. Any easements for permanent structures or permanent changes in existing facilities are to be obtained and paid for by the Owner. All additional lands and access thereto required for temporary construction facilities, construction equipment, or storage of materials and equipment to be incorporated in the Work are to be obtained and paid for by Contractor.

ARTICLE 7 - INTERPRETATIONS AND ADDENDA

- 7.01 All questions about the meaning or intent of the Bidding Documents are to be submitted to the Town of Penfield Town Engineer in writing. Interpretations or clarifications considered necessary by Engineer in response to such questions will be issued by Addenda mailed or delivered to all parties recorded by Engineer as having received the Bidding Documents. Questions received less than five days prior to the date for opening of Bids

INSTRUCTIONS TO BIDDERS

may not be answered. Only questions answered by Addenda will be binding. Oral and other interpretations or clarifications will be without legal effect.

- 7.02 Addenda may be issued to clarify, correct, or change the Bidding Documents as deemed advisable by Owner or Engineer.

ARTICLE 8 - BID SECURITY

- 8.01 No bid bond will be required for the project

ARTICLE 9 - CONTRACT TIMES

- 9.01 The number of days within which, or the dates by which, the Work is to be substantially completed and ready for final payment are set forth in the Agreement. The Town of Penfield is requesting construction to start immediately upon The Penfield Town Board awarding the bid by town resolution to allow for proper soil stabilization and seeding prior to the winter months.

ARTICLE 10 - LIQUIDATED DAMAGES

- 10.01 Provisions for liquidated damages, if any, are set forth in the Agreement.

ARTICLE 11 - SUBSTITUTE AND "OR-EQUAL" ITEMS

- 11.01 The Contract, if awarded, will be on the basis of materials and equipment specified or described in the Bidding Documents, or "or-equal" materials and equipment as defined in the Storm specifications, or those substitute materials and equipment approved by the Engineer and identified by Addendum. The materials and equipment described in the Bidding Documents establish a standard of required type, function and quality to be met by any proposed substitute or "or-equal" item. Request for Engineer's clarification of materials and equipment considered "or-equal" prior to the Effective Date of the Agreement must be received by the Engineer at least 5 days prior to the date for receipt of Bids. No item of material or equipment will be considered by Engineer as a substitute unless written request for approval has been submitted by Bidder and has been received by Engineer at least 7 days prior to the date for receipt of Bids. The burden of proof of the merit of the proposed item is upon the Bidder. Engineer's decision of approval or disapproval of a proposed item will be final. If Engineer approves any proposed substitute item, such approval will be set forth in an Addendum issued to all prospective Bidders. Bidders shall not rely upon approvals made in any other manner.

ARTICLE 12 - SUBCONTRACTORS, SUPPLIERS, AND OTHERS

- 12.01 If the Supplementary Conditions require the identity of certain Subcontractors, Suppliers, individuals, or entities to be submitted to Owner in advance of a specified date prior to the Effective Date of the Agreement, the apparent Successful Bidder, and any other Bidder so requested, shall within five days after Bid opening, submit to Owner a list of all such Subcontractors, Suppliers, individuals, or entities proposed for those portions of the Work for which such identification is required. Such list shall be accompanied by an experience statement with pertinent information regarding similar projects and other evidence of qualification for each such Subcontractor, Supplier, individual, or entity if requested by Owner. If Owner or Engineer, after due investigation, has reasonable objection to any proposed Subcontractor, Supplier, individual, or entity, Owner may, before the Notice of Award is given, request apparent Successful Bidder to submit a substitute, without an increase in the Bid.
- 12.02 If apparent Successful Bidder declines to make any such substitution, Owner may award the Contract to the next lowest Bidder that proposes to use acceptable Subcontractors, Suppliers, individuals, or entities. Declining to make requested substitutions will not constitute grounds for forfeiture of the Bid security of any Bidder. Any Subcontractor, Supplier, individual, or entity so listed and against which Owner or Engineer makes no written objection prior to the giving of the Notice of Award will be deemed acceptable to Owner and Engineer subject

INSTRUCTIONS TO BIDDERS

to revocation of such acceptance after the Effective Date of the Agreement as provided in Paragraph 6.06 of the General Conditions.

- 12.03 Contractor shall not be required to employ any Subcontractor, Supplier, individual, or entity against whom Contractor has reasonable objection.

ARTICLE 13 - PREPARATION OF BID

- 13.01 The Bid Form is included with the Bidding Documents. Additional copies may be obtained from the Engineer.
- 13.02 All blanks on the Bid Form shall be completed by printing in ink or by typewriter and the Bid signed in ink. Erasures or alterations shall be initialed in ink by the person signing the Bid Form. A Bid price shall be indicated for each Bid item and unit price item listed therein, or the words "No Bid," "No Change," or "Not Applicable" entered.
- 13.03 A Bid by a corporation shall be executed in the corporate name by the president or a vice-president or other corporate officer accompanied by evidence of authority to sign. The corporate seal shall be affixed and attested by the secretary or an assistant secretary. The corporation address and state of incorporation shall be provided on the Bid Form.
- 13.04 A Bid by a partnership shall be executed in the partnership name and signed by a partner (whose title must appear under the signature), accompanied by evidence of authority to sign. The official address of the partnership shall be provided on the Bid Form.
- 13.05 A Bid by a limited liability company shall be executed in the name of the firm by a member and accompanied by evidence of authority to sign. The state of formation of the firm and the official address of the firm must be provided on the Bid Form.
- 13.06 A Bid by an individual shall show the Bidder's name and business address.
- 13.07 A Bid by a joint venture shall be executed by each joint venturer in the manner indicated on the Bid Form. The business address of the joint venture must be provided on the Bid Forms.
- 13.08 All names shall be typed or printed in ink below the signatures.
- 13.09 The Bid shall contain an acknowledgment of receipt of all Addenda, the numbers of which shall be filled in on the Bid Form.
- 13.10 The postal and e-mail address and telephone number for communications regarding the Bid shall be shown.
- 13.11 The Bid shall contain evidence of Bidder's authority and qualification to do business in the state or locality where the Project is located or Bidder shall covenant in writing to obtain such qualification prior to award of the Contract and attach such covenant to the Bid. Bidder's state contractor license number, if any, shall also be shown on the Bid Form.

ARTICLE 14 - BASIS OF BID; COMPARISON OF BIDS

14.01 *Unit Price*

- A. Bidders shall submit a Bid on a unit price basis for each item of Work listed in the Bid schedule.

INSTRUCTIONS TO BIDDERS

- B. Bid award will be based on the total cost of the complete sports field construction including all associated drainage and soil stabilization requirements.
- C. Discrepancies between the multiplication of units of Work and unit prices will be resolved in favor of the unit prices. Discrepancies between the indicated sum of any column of figures and the correct sum thereof will be resolved in favor of the correct sum. Discrepancies between words and figures will be resolved in favor of the words.
- D. Bidder shall submit a separate price for each alternate described in the Bidding Documents as provided for in the Bid Form. The price for each alternate will be the amount added to the Bid if Owner selects the alternate. In the comparison of Bids, alternates will be applied in the same order as listed in the Bid form.

ARTICLE 15 - SUBMITTAL OF BID

- 15.01 With each copy of the Bidding Documents, a Bidder is furnished one separate unbound copy of the Bid Form, and the Bid Bond Form. The unbound copy of the Bid Form is to be completed and submitted with all the attachments outlined in the Bid Form.
- 15.02 A Bid shall be submitted and received no later than the date and time prescribed and at the place indicated in the Advertisement or Invitation to Bid and shall be enclosed in an opaque sealed envelope plainly marked with the Project title (and, if applicable, the designated portion of the Project for which the Bid is submitted), the name and address of Bidder, and shall be accompanied by the other required documents. If a Bid is sent by mail or other delivery system, the sealed envelope containing the Bid shall be enclosed in a separate envelope plainly marked on the outside with the notation "BID ENCLOSED." When using the mail or other delivery system, the Bidder is totally responsible for the mail or other delivery system delivering the Bid at the place and prior to the time indicated in the Advertisement for Bid. A mailed Bid shall be addressed to Owner at address in the Bid Form.

ARTICLE 16 - MODIFICATION AND WITHDRAWAL OF BID

- 16.01 A Bid may be modified or withdrawn by an appropriate document duly executed in the manner that a Bid must be executed and delivered to the place where Bids are to be submitted prior to the date and time for the opening of Bids.
- 16.02 If within 24 hours after Bids are opened, any Bidder files a duly signed written notice with Owner and promptly thereafter demonstrates to the reasonable satisfaction of Owner that there was a material and substantial mistake in the preparation of its Bid, that Bidder may withdraw its Bid. Thereafter, if the Work is rebid or negotiated, that Bidder will be disqualified from further bidding on the Work.

ARTICLE 17 - OPENING OF BIDS

- 17.01 Bids will be opened at the time and place indicated in the Advertisement and, unless obviously non-responsive, read aloud publicly. An abstract of the amounts of the Bids and major alternates, if any, will be made available to Bidders after the opening of Bids.

ARTICLE 18 - BIDS TO REMAIN SUBJECT TO ACCEPTANCE

- 18.01 All Bids will remain subject to acceptance for the period of time stated in the Bid Form, but Owner may, at its sole discretion, release any Bid and return the Bid security prior to the end of this period.

INSTRUCTIONS TO BIDDERS

ARTICLE 19 – EVALUATION OF BIDS AND AWARD OF CONTRACT

- 19.01 Owner reserves the right to reject any or all Bids, including without limitation, nonconforming, nonresponsive, unbalanced, or conditional Bids. Owner further reserves the right to reject the Bid of any Bidder whom it finds, after reasonable inquiry and evaluation, to not be responsible. Owner also reserves the right to waive all informalities not involving price, time, or changes in the Work and to negotiate contract terms with the Successful Bidder.
- 19.02 More than one Bid for the same Work from an individual or entity under the same or different names will not be considered. Reasonable grounds for believing that any Bidder has an interest in more than one Bid for the Work may be cause for disqualification of that Bidder and the rejection of all Bids in which that Bidder has an interest.
- 19.03 In evaluating Bids, Owner will consider whether or not the Bids comply with the prescribed requirements, and such alternates, unit prices and other data, as may be requested in the Bid Form or prior to the Notice of Award.
- 19.04 In evaluating Bidders, Owner will consider the qualifications of Bidders and may consider the qualifications and experience of Subcontractors, Suppliers, and other individuals or entities proposed for those portions of the Work for which the identity of Subcontractors, Suppliers, and other individuals or entities must be submitted as provided in the Supplementary Conditions.
- 19.05 Owner may conduct such investigations as Owner deems necessary to establish the responsibility, qualifications, and financial ability of Bidders, proposed Subcontractors, Suppliers, individuals, or entities to perform the Work in accordance with the Contract Documents.
- 19.06 If the Contract is to be awarded, Owner will award the Contract to the responsible Bidder whose Bid, conforming with all the material terms and conditions of the Instructions to Bidders, is lowest, price and other factors considered.

ARTICLE 20 - CONTRACT INSURANCE

- 20.01 The General Conditions, as may be modified by the Supplementary Conditions, sets forth Owner's requirements as to insurance. When the Successful Bidder delivers the executed Agreement to Owner, it shall be accompanied by such bonds.

ARTICLE 21 - SIGNING OF AGREEMENT

- 21.01 When Owner gives a Notice of Award to the Successful Bidder, it shall be accompanied by the required number of unsigned counterparts of the Agreement with the other Contract Documents which are identified in the Agreement as attached thereto. Within 15 days thereafter, Successful Bidder shall sign and deliver the required number of counterparts of the Agreement and attached documents to Owner. Within ten days thereafter, Owner shall deliver one fully signed counterpart to Successful Bidder with a complete set of the Drawings with appropriate identification.

ARTICLE 23 - SALES AND USE TAXES

- 23.01 Owner is exempt from Owner State sales and use taxes on materials and equipment to be incorporated in the Work. Said taxes shall not be included in the Bid.

ARTICLE 24 – WAGE RATE REQUIREMENTS

- 25.01 The prevailing wage rates of the State of Project State apply to this contract as do any requirements of the State of Project State associated with the use of these State Prevailing wages.

SPECIFICATIONS/ DETAILS

SPECIFICATIONS

for

2021 ROTHFUSS PARK SPORTS FIELD PROJECT

The Town of Penfield Engineering Department, on behalf of the Penfield Town Board, is seeking unit price bids for the following classifications of three (3) multi-purpose sports fields with associated drainage.

The following minimum specifications shall apply to the:

I Materials

A) General

All materials shall be new and free of defects.

B) Storm Sewers

- Corrugated polyethylene pipe (CPP) smooth flow/double wall meeting the requirements of ASTM D3350 with water tight joints.

Each pipe system shall be designed as to proper strength classification by the developer's professional engineer and the pipe material, thickness and diameter shall be stated on the plans. Heights of cover, nature of foundation soil, type of bedding and trench width shall be considered in specifying the pipe. Developer shall be responsible for providing extra strength bedding, cradle or encasement if the design conditions cannot be met in the field. Whenever the storm sewer is under the road, the town requires that the developer's engineer specify the correct class for H-20 loading at the sewer depth.

C) Manholes and Catch Basins

- Storm sewer manholes and catch basins shall be constructed in conformance with ASTM C478 and the details shown on the Standard Detail drawings in the appendix of these documents.

D) Installation

Installation of all storm sewers, laterals, manholes and catch basins shall be in conformance with the installation requirements as specified under these specifications, as well as, the requirements of the standard detail drawing provided herein.

Storm sewers shall have a minimum cover of three (3') feet wherever vehicular traffic is anticipated and provide for a minimum cover of two (2') feet from top of pipe to the road subgrade.

All joints shall be connected with gaskets or mechanical collars, as recommended by the manufacturer.

E) Testing

The entire storm sewer system shall be visually inspected for smoothness of invert, freedom from obstructions and straightness of line. A final inspection of the system will be done prior to release of payment for that line item. At that time the system shall be clean, free of mud and debris and manholes will be adjusted to final grade.

Prior to dedication of the storm or sanitary sewer system to the Town of Penfield, or a release of the Letter of Credit; the pipes, catch basins and manholes shall be properly flushed. This item shall be included in the contract bid price. If the Town of Penfield needs to flush the system prior to inspecting, the developer will be charged for the labor and equipment utilized. The Town of Penfield reserves the right to require the storm sewers to be flushed and cleaned at other times if proper erosion and sediment control practices are not met.

If the final inspected condition of the storm system is altered by work in future sections, the Town of Penfield may hold contingency money for remediation of the same. The developer shall flush all storm sewers after completion of the final phase of a development.

I. Pavement Restoration

- A) For the removal and replacement of existing pavement for the installation of the storm sewer, the contractor shall provide four prices for pavement restoration per square foot as follows:
- (a) 12" compacted stone base
 - (b) 3" of #1 dense binder installed
 - (c) 1.5" of Type 7 top course installed
 - (d) 1.5" milling of road
- B) At the time of pavement restoration the Town may specify additional areas which they feel should be paved or areas where pavement restoration should be extended to provide ease of, or safer access. This will be done on an as needed basis to be determined by the Engineering Department.
- C) All existing pavement edges shall be saw cut square.
- D) All existing base areas shall be trimmed with #1 crusher run and compacted with either a 2 ton steel wheel roller or a plate tamper.

- E) Asphalt shall be raked to provide a uniform thickness and surface texture flush to sidewalks and the existing pavement. The pavement shall then be rolled with a 2 ton steel wheel roller. Hand tampers or plate tampers will not be allowed unless the width of the patch will not allow the roller. Where existing asphalt driveway is top coated, it shall be keyed into the existing asphalt a minimum of 1”.
- F) All exposed edges shall be tamped with a hand tamper on a 45 angle.
- G) Where new pavement abuts old, the edge shall be thoroughly coated with tack coat and applied by brushing.
- H) Driveways shall not be left closed more than 48 hours or over a weekend or holiday. Contractor to provide plates or other means of access at their cost.

III. Topsoil

- A) Topsoil may be naturally occurring or manmade. Topsoil shall be screened and free from refuse, material toxic or otherwise deleterious to plant growth, subsoil woody vegetation and stumps, roots, brush, stones, clay lumps, or similar objects. Manufactured topsoil shall consist of a mineral compound and amendments to meet the specified organic content and other requirements. Sod and herbaceous growth such as grass and weeds need not be removed but shall be thoroughly broken up and mixed with the soil during handling or manufacturing operations.
- B) The pH of the material shall be between 5.5 and 7.6.
- C) The organic content shall be not less than 2% or more than 20%.
- D) The maximum size of all objects shall be 50 mm (2”).
- E) Town of Penfield may request testing of any topsoil that is not deemed to meet the specifications.
- F) Provide a minimum of 6” of topsoil in all lawn areas.

IV. Protection of Incomplete Work

- A) It shall be the responsibility of the contractor to supply any and all public safety devices including but not limited to barricades, flashers, cones, traffic control signs, or flagmen these devices shall be maintained throughout the duration of the project.

V. Method of Payment

- A) All payments will be made based on the unit prices listed on the bid sheet multiplied by footage mutually agreed upon by the Contractor and the Engineering Department.
- B) This is a prevailing wage contract and the Town of Penfield, as contracting agency, is responsible to insure that prevailing wages are being paid to employees who work on this project. The contractor is required to submit a certified payroll audit, which shows hourly wages paid to all employees. The Town will hold a 5% retainage until said statement has been submitted.

VI. Maintenance Bonds

- A) The contractor will be required to submit a maintenance bond in the amount of 10% of the total cost of the associated project. The term of the maintenance bond shall be 2 years from the date of acceptance.

VII. Schedule

- A) Contractor shall commence work within 14 days of their Notice to Proceed and shall be completed no later than September 30, 2021.
- B) All lawn and pavement repairs shall be restored within 7 days of material placement.

VIII. Maintenance & Protection of Traffic

- A) Contractor is responsible that all requirements for the maintenance and protection of traffic are complied with, as established by the authorized agency. Contractor shall conduct all work to maintain a safe site for the workers, pedestrians, and vehicular traffic. Contractor to provide flagmen, as required, with appropriate safety equipment. All work shall be protected at night, weekends, and holidays, as authorized by the town's project representative. This can include, but is not limited to, barricades, flashers, plates, cones, or other methods necessary.

X. Indemnity

- A) Contractor covenants and agrees to indemnify and hold harmless the Town, its Officers, Agents and Employees, from and against any and all liability, loss, demands, damages, actions or causes of action, including attorneys' fees and court costs, due to loss of life, personal injury and/or damage to property, arising directly or indirectly from the work performed by Contractor, its officers, employees, agents, subcontractors, and/or any other party performing work on the project at Contractor's request.

XI. Insurance

- A) Contractor shall name the Town as an additional insured on its commercial general liability policy with minimum limits of \$1,000,000 per occurrence/\$2 million general aggregate on a primary and non-contributory basis and provide a Certificate of Insurance evidencing such coverage prior to commencement of the work. Any subcontractors retained on the project by Contractor must also comply with this requirement.

TOWN OF PENFIELD

STANDARD DETAIL #12

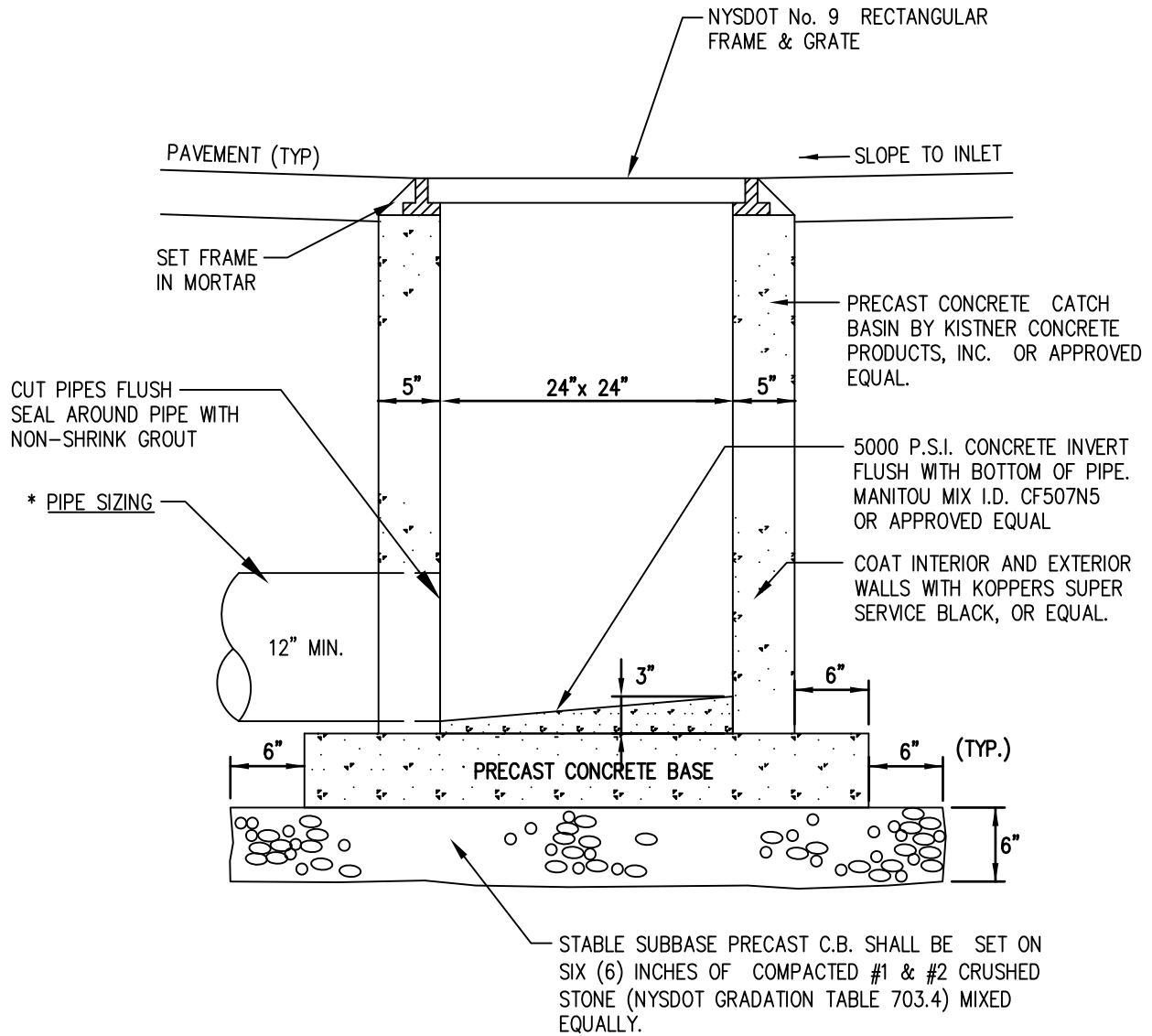

FIELD INLET DETAIL

(N.T.S.)

TOWN OF PENFIELD

STANDARD DETAIL #32

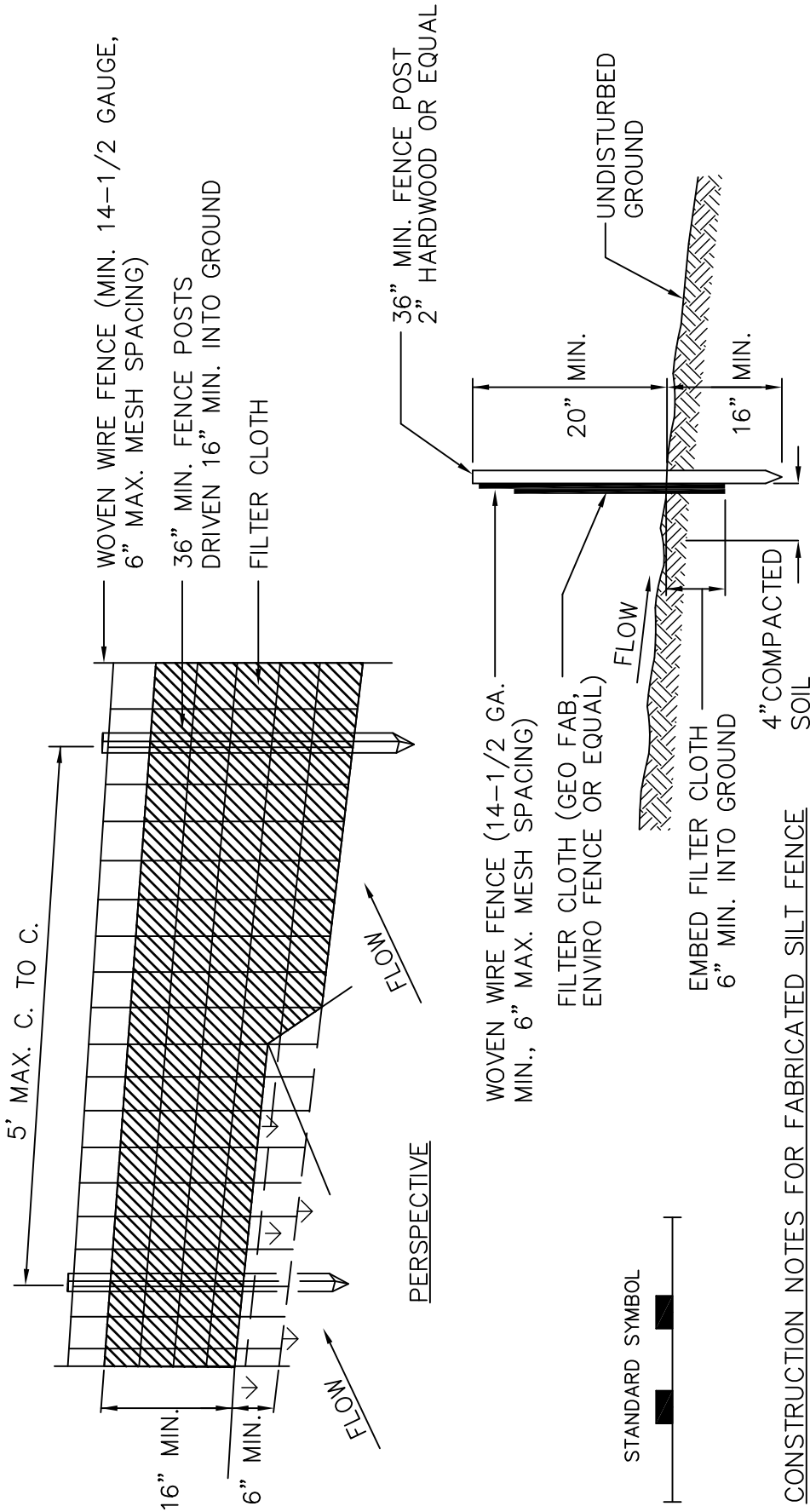

SECTION

POSTS: STEEL, EITHER T OR U TYPE OR 2" HARDWOOD
FENCE: WOVEN WIRE, 14-1/2 GAUGE, 6" MAX. MESH OPENING
FILTER CLOTH: FILTER X, MIRAFI 100X, STABILINKA T140N OR PREFABRICATED GEOFAB, ENVIROFENCE OR APPROVED EQUAL

CONSTRUCTION NOTES FOR FABRICATED SILT FENCE

1. WOVEN WIRE FENCE TO BE FASTENED SECURELY TO FENCE POSTS WITH WIRE TIES OR STAPLES.
2. FILTER CLOTH TO BE FASTENED SECURELY TO WOVEN WIRE FENCE WITH TIES SPACED EVERY 24" AT TOP AND MID SECTION.
3. WHEN TWO SECTIONS OF FILTER CLOTH ADJOIN EACH OTHER, THEY SHALL BE OVERLAPPED BY SIX INCHES AND FOLDED.
4. MAINTENANCE SHALL BE PERFORMED AS NEEDED AND MATERIAL REMOVED WHEN CAPTURED SEDIMENT BECOMES 6" THICK.

SILT FENCE

(N.T.S.)

TOWN OF PENFIELD

STANDARD DETAIL #34

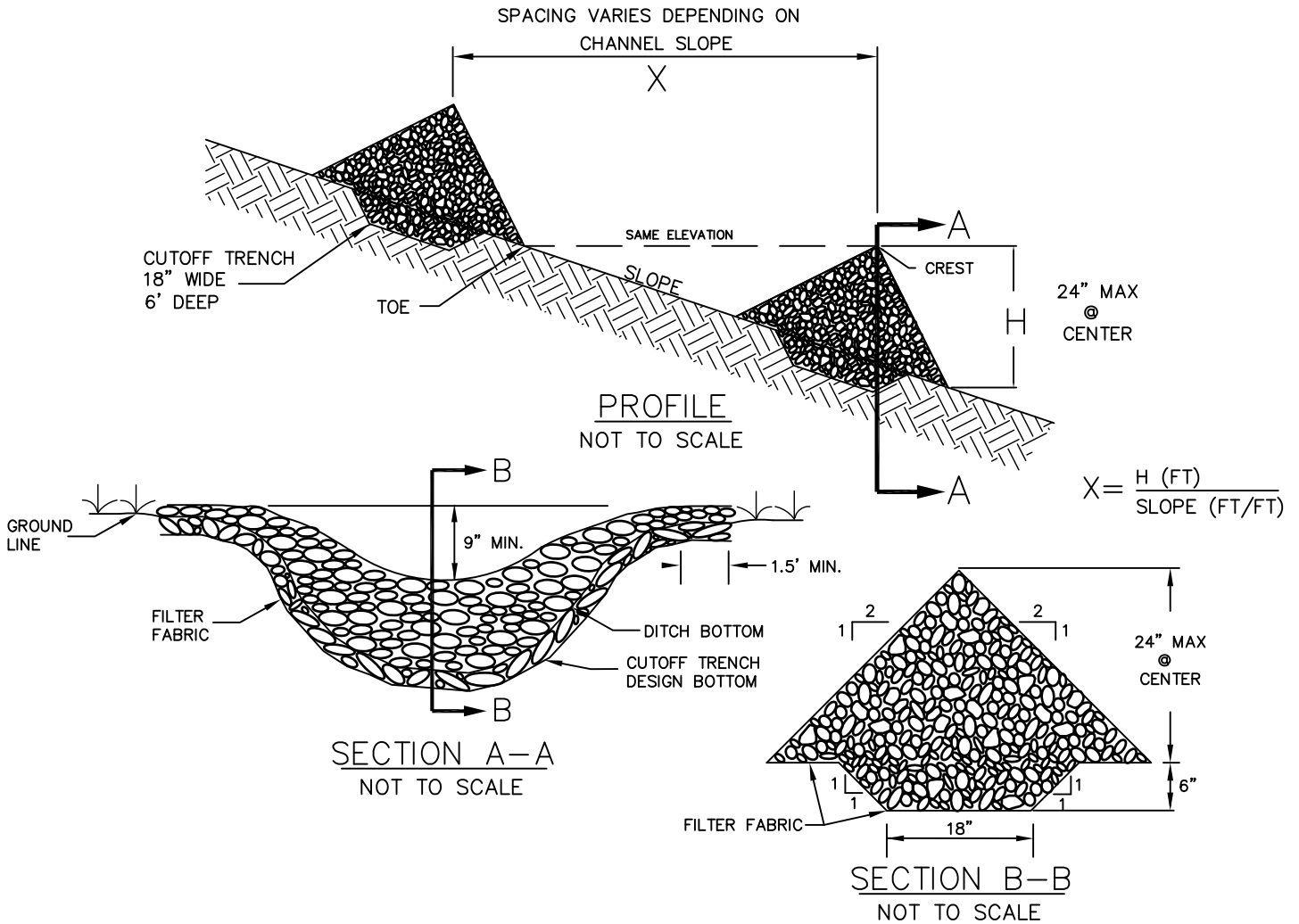

CONSTRUCTION SPECIFICATIONS

- 1.) STONE WILL BE PLACED ON A FILTER FABRIC FOUNDATION TO THE LINES, GRADES AND LOCATION SHOWN IN THE PLAN.
- 2.) SET SPACING OF CHECK DAMS TO ASSUME THAT THE ELEVATIONS OF THE CREST OF THE DOWNSTREAM DAM IS AT THE SAME ELEVATION OF THE TOE OF THE UPSTREAM DAM.
- 3.) EXTEND THE STONE A MINIMUM OF 1.5 FEET BEYOND THE DITCH BANKS TO PREVENT CUTTING AROUND THE DAM.
- 4.) PROTECT THE CHANNEL DOWNSTREAM OF THE LOWEST CHECK DAM FROM SCOUR AND EROSION WITH STONE OR LINER AS APPROPRIATE.
- 5.) ENSURE THAT CHANNEL APPURTENANCES SUCH AS CULVERT ENTRANCES BELOW CHECK DAMS ARE NOT SUBJECT TO DAMAGE OR BLOCKAGE FROM DISPLACED STONES.

MAXIMUM DRAINAGE AREA - 2 ACRES

CHECK DAM DETAIL

(N.T.S.)

REVISED: 2019

TOWN OF PENFIELD

STANDARD DETAIL #35

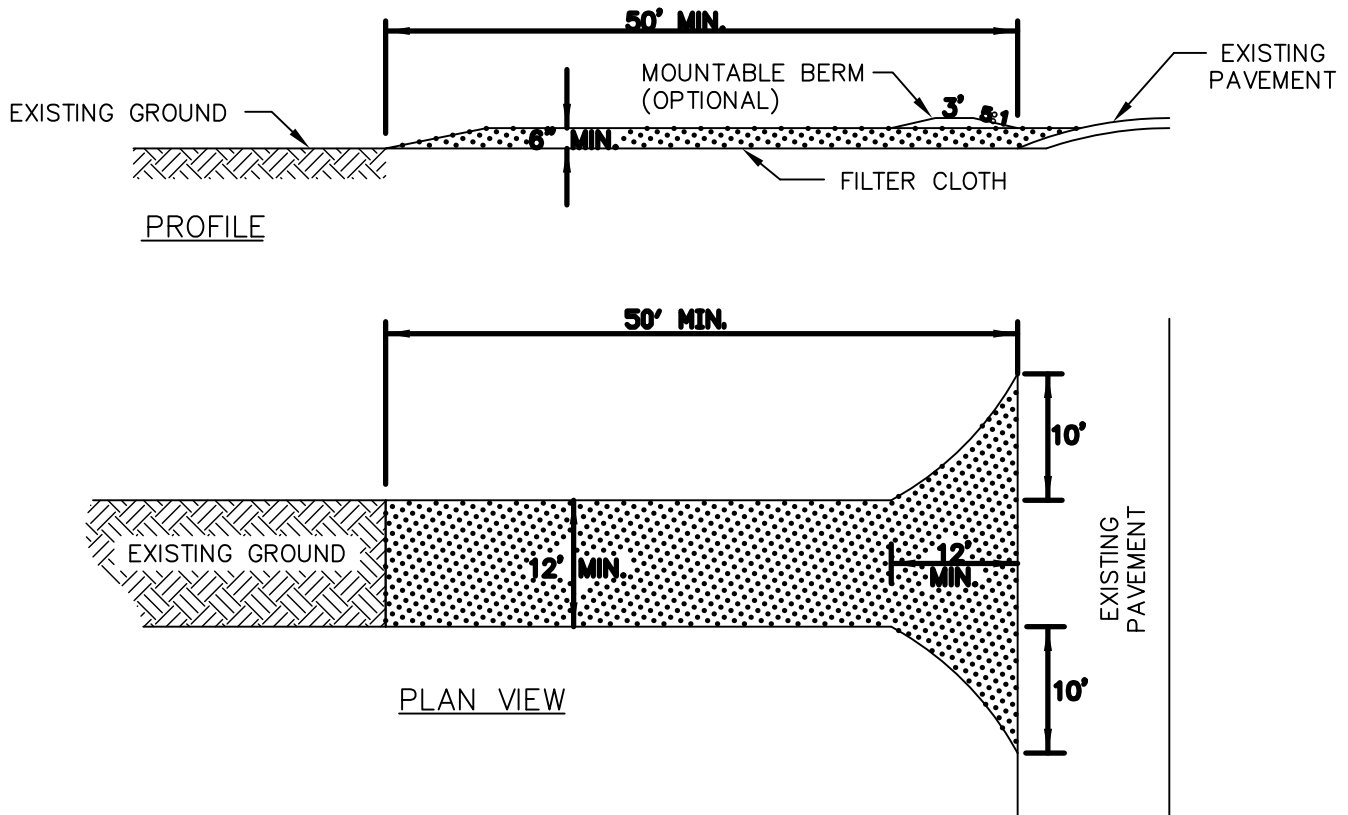

CONSTRUCTION SPECIFICATIONS

1. STONE SIZE – USE 1–4 INCH STONE, OR RECLAIMED OR RECYCLED CONCRETE EQUIVALENT.–
2. LENGTH – AS REQUIRED, BUT NOT LESS THAN 50 FEET (EXCEPT ON A SINGLE RESIDENCE LOT WHERE A 30 FOOT MINIMUM LENGTH WOULD APPLY).
3. THICKNESS – NOT LESS THAN SIX (6) INCHES.
4. WIDTH – TWELVE (12) FEET MINIMUM, BUT NOT LESS THAN THE FULL WIDTH AT POINTS WHERE INGRESS OR EGRESS OCCUR. TWENTY–FOUR (24) FOOT IF SINGLE ENTRANCE TO SITE
5. GEOTEXTILE – WILL BE PLACED OVER THE ENTIRE AREA PRIOR TO PLACING OF STONE.
6. SURFACE WATER – ALL SURFACE WATER FLOWING OR DIVERTED TOWARD CONSTRUCTION ENTRANCES SHALL BE PIPED BENEATH THE ENTRANCE. IF PIPING IS IMPRACTICAL, A MOUNTABLE BERM WITH 5:1 SLOPES WILL BE PERMITTED.
7. MAINTENANCE – THE ENTRANCE SHALL BE MAINTAINED IN A CONDITION WHICH WILL PREVENT TRACKING OR FLOWING OF SEDIMENT ONTO PUBLIC RIGHT–OF–WAY. THIS MAY REQUIRE PERIODIC TOP DRESSING WITH ADDITIONAL STONE AS CONDITIONS DEMAND AND REPAIR AND/OR CLEANOUT OF ANY MEASURES USED TO TRAP SEDIMENT. ALL SEDIMENT SPILLED, DROPPED, WASHED OR TRACKED ONTO PUBLIC RIGHT–OF–WAYS MUST BE REMOVED IMMEDIATELY.
8. WASHING – WHEELS SHALL BE CLEANED TO REMOVE SEDIMENT PRIOR TO ENTRANCE ONTO PUBLIC RIGHT–OF–WAY. WHEN WASHING IS REQUIRED, IT SHALL BE DONE ON AN AREA STABILIZED WITH STONE AND WHICH DRAINS INTO AN APPROVED SEDIMENT TRAPPING DEVICE.
9. PERIODIC INSPECTION AND NEEDED MAINTENANCE SHALL BE PROVIDED AFTER EACH RAIN.

STABILIZED CONSTRUCTION ENTRANCE

(N.T.S.)

REVISED: 2019

TOWN OF PENFIELD

STANDARD DETAIL

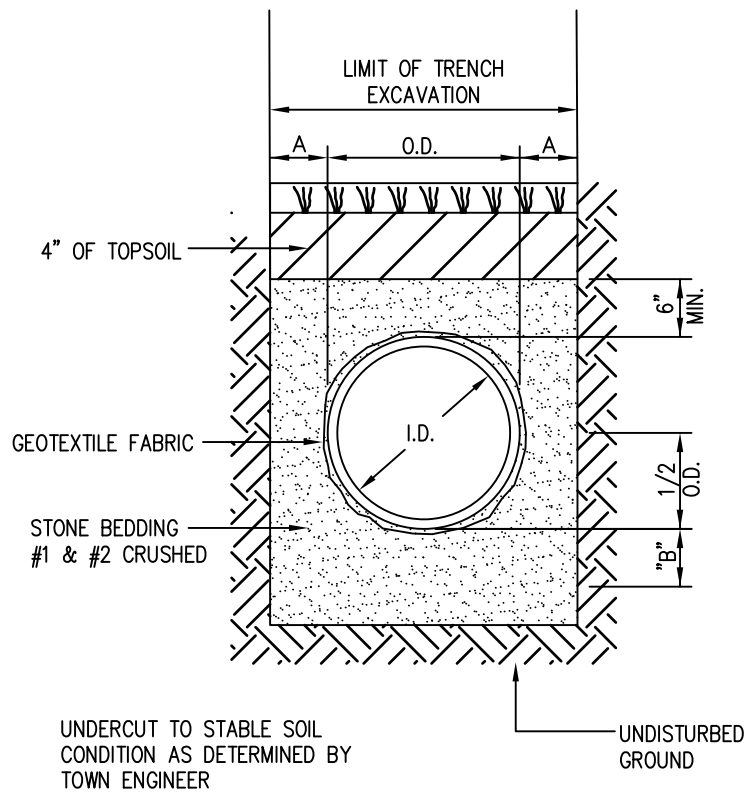

PIPE DIA.	"A"	"B"
UP TO 18"	1'-0"	6"
21" TO 36"	1'-6"	9"
OVER 36"	2'-0"	12"

PERFORATED STORM SEWER

BEDDING DETAIL

(N.T.S.)

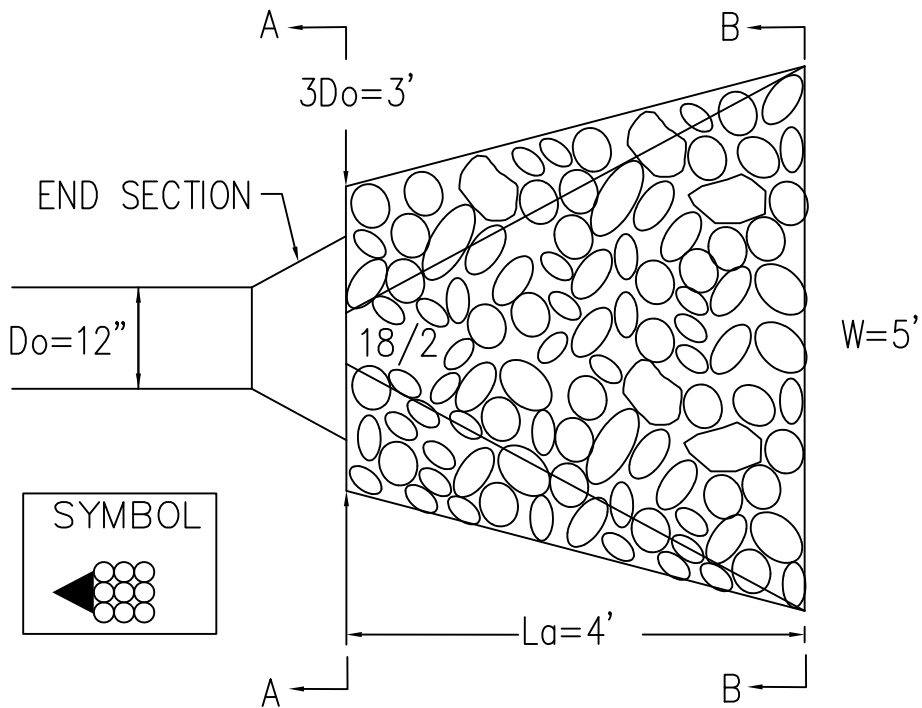

PLANVIEW

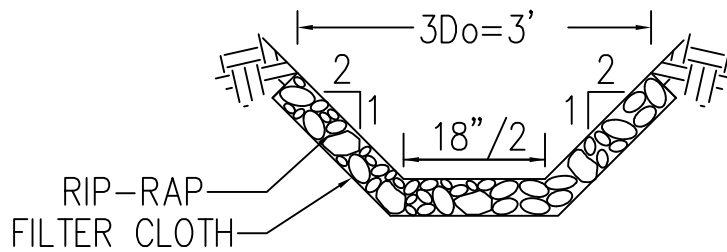

CROSS SECTION A-A

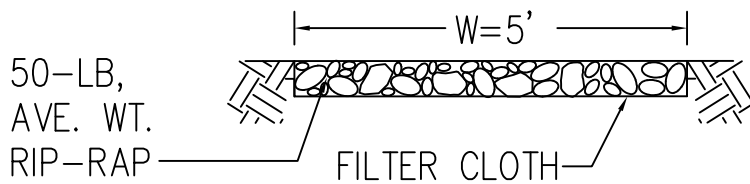

CROSS SECTION B-B

RIP-RAP OUTLET PROTECTION DETAIL

(N.T.S.)

BID SHEET

TOWN OF PENFIELD

2021 ROTHFUSS PARK SPORTS FIELD PROJECT BID SHEET

ITEM #1 GRADING & EROSION CONTROL – Installation (base bid)

Price to grade/ shape three (3) multi-purpose sports fields including all associated new storm sewer, erosion control measures and lawn restoration with screened topsoil and seed per the attached specifications, including all labor, material, equipment:

	# Unit	Unit Price	Total
A) Mobilization (Maximum 5% of total base bid)	1	LS x \$	LS = \$
B) Maintenance and Protection of Traffic (Maximum 5% of total base bid)	1	LS x \$	LS = \$
C) 12” Perf. CPP Storm Sewer Pipe, 0’ to 12’ depth	990	LF x \$	LF = \$
D) 24” X 24” Precast Reinf. Concrete Field Inlet, Complete	4	EA x \$	EA = \$
E) 12” Galvanized End Section Complete	1	EA x \$	EA = \$
F) Excavation and Grading, with Compaction	8,610	CY x \$	CY = \$
G) Strip and Stockpile Topsoil	995	CY x \$	CY = \$
H) Clear and Grub Complete	1	LS x \$	LS = \$
I) Sift and Process Topsoil Complete	1	LS x \$	LS = \$
J) Install & Maintain Silt Fence, Inc. Removal Complete	1,256	LF x \$	LF = \$
K) Install & Maintain Stone Check Dams, Inc. Removal Complete	1	EA x \$	EA = \$
L) 50LB Average Weight Rip Rap	5	SY x \$	SY = \$
M) Permanent Seeding of Area Inc. Replacement of Screened Topsoil from Onsite Sources, Hydroseed with mulch and Tackifer, Complete	9.8	AC x \$	AC = \$
N) Install & Maintain Orange Construction Fence, Inc. Removal Complete	1,300	LF x \$	LF = \$

BID TOTAL _____

I have received, read and agree to the terms and conditions as set forth in the specifications. I hereby recognize and agree that upon execution of this document by an authorized officer of the Town of Penfield, that this document, together with the Contractor's bid/proposal as accepted by the Town of Penfield and all other documents prepared by or on behalf of the Town of Penfield for this solicitation, shall become the binding contract between the parties for the services to be provide in accordance with the terms and conditions set forth herein.

Firm Name _____ Signed By _____

Address _____ Printed Name _____

_____ Title _____

Federal ID # _____ Phone Number _____

Bid Acceptance and Contract Award

Upon award of the Penfield Town Board per resolution # _____ and by these signatures, the parties agree to all the terms, conditions and provisions of the bid proposal. The above Contractor's bid is accepted, except as noted, and the contract is awarded

Date: _____

By: _____

R. Anthony LaFountain, Supervisor

BID PROPOSAL REQUIREMENTS

NON-COLLUSIVE BIDDING CERTIFICATE

The Bidder specifically agrees to the provisions of Section 103-d of General Municipal Law. Pursuant to the non-collusive bidding certification provided herein, by submission of this bid, each bidder and each person signing on behalf of any bidder certifies, and in case of a joint bid, each party thereto certifies as to its own organization, under penalty of perjury, that to the best of knowledge and belief:

- (1) The prices in this bid have been arrived at independently without collusion, consultation, communication, or agreement, for the purpose of restricting competition, as to any matter relating to such prices with any other bidder or with any competitor.
- (2) Unless otherwise required by law, the prices which have been quoted in this bid have not knowingly disclosed by the bidder and will not knowingly be disclosed by the bidder prior to opening, directly or indirectly, to any other bidder or to any competitor; and,
- (3) No attempt has been made or will be made by the bidder to include any other person, partnership, or corporation to submit or not to submit or not to submit a bid for the purpose of restricting competition.

NAME OF PROJECT _____

NAME OF BIDDER _____

AUTHORIZED SIGNATURE _____

DATE _____

CERTIFICATION OF SMALL AND M/WBE UTILIZATION

Monroe County and HUD encourage the participation of **small and minority business enterprises (MBE) and women's business enterprises (WBE)** in all federally financed and assisted construction projects administered by the County.

In accordance with Part 85.36, (e), HUD Procurement Standards, the Contractor and all subcontractors must comply with the following requirements for contracting with these firms:

The Contractor and all subcontractors will take affirmative steps to assure that small and M/WBE enterprises are used whenever possible. These affirmative steps include:

- Placing qualified small and M/WBE enterprises on solicitation lists;
- Assuring that small and M/WBE enterprises are solicited whenever they are potential sources;
- Dividing total requirements, when economically feasible, into smaller tasks or quantities to permit maximum participation by small and M/WBE enterprises;
- Establishing delivery schedules, where the requirement permits, which encourage participation by small and M/WBE enterprises;
- Using the services and assistance of the Small Business Administration, and the Minority Business Development Agency of the Department of Commerce; and
- If subcontracts are to be let, the subcontractor must also take the affirmative steps listed above.

The BIDDER certifies that he/she will take the affirmative steps to utilize small and M/WBE enterprises to the greatest extent feasible as members of the workforce, as subcontractors, and/or as suppliers on the project named below:

	(Name of Project)
BIDDER'S NAME	
COMPANY NAME	
ADDRESS	
FED. ID/IRS NUMBER	
Signature	Date

MAPPING



GRADING NOTES:

- EXISTING UNDERGROUND UTILITIES SHOWN HEREON WERE PLOTTED FROM FIELD LOCATIONS AND/OR UTILTY COMPANY RECORDS. A MINIMUM OF 8 FEET FROM THE PROPOSED SUT SHALL BE MAINTAINED. ALL UTILITIES SHALL BE DELETED AT 1'-80'-86"-7962 FOR STAKE-OUT OF EXISTING UTILITIES.
- THE CONTRACTOR SHALL CONTROL DUST ON-SITE AS DIRECTED BY THE TOWN OF PENFIELD.
- THE GRADING DESIGN ASSUMES AN AVERAGE TOPSOIL DEPTH OF 8 INCHES ACROSS THE SITE. IF SITE CONDITIONS DEVIATE FROM THIS BY MORE THAN 3", THE CONTRACTOR IS TO NOTIFY THE ENGINEER.
- TOPSOIL IS TO BE STRIPPED FROM ALL PROPOSED DISTURBANCE AREAS AND STOCKPILED IN THE DESIGNATED AREA SHOWN ON THE PROJECT PLANS.
- 6" TOPSOIL TO BE REPLACED IN ALL DISTURBED LANDSCAPED AREAS.
- THE EARTHWORK ANALYSIS IS BASED ON ASSUMPTIONS FOR TOPSOIL DEPTH, SHRINKAGE AND COMPACTION. ACTUAL FIELD CONDITIONS MAY VARY FROM THE ASSUMPTIONS. THE CONTRACTOR SHALL VERIFY FIELD CONDITIONS WITH THE ENGINEER IF CONDITIONS VARY FROM THE DESIGN PARAMETERS.

LANDSCAPE NOTES:

- SEED ALL AREAS NOT PAVED, PLANTED OR SPECIFIED OTHERWISE WITH LAWN SEED. A LAWN SEED MIXTURE SHALL BE PROVIDED AS FOLLOWS:

PERennial, THE GRASS, & WARMING STAIR	% BY WEIGHT	% BY PURITY	% GRAM
PERennial, THE GRASS, & WARMING STAIR	40	85	85
BARON & MOUNTAIN	20	97	80
KENTUCKY BLUEGRASS	40	85	80

SEEDING RATE: 6.0 LBS PER 1,000 SF.
MULCH: STRAW AT TWO TONS PER ACRE, OR WOOD CHIP MULCH USED WITH A HYDROSEEDING APPLICATION METHOD, WITH TACKLER.
SPRING FERTILIZER: 5-10-10 AT 20 LBS PER 1,000 SF.

SEQUENCE OF CONSTRUCTION STEPS:

STEP 1: (SITE PREPARATION)

- INSTALL AND MAINTAIN STABILIZED CONSTRUCTION ENTRANCE (SEE DETAIL).
- CLEAR AND GRUB AS REQUIRED FOR SILT FENCE INSTALLATION.
- INSTALL PERIMETER SILT FENCE, COMPLETE CLEANING AND GRUBBING OPERATIONS.

STEP 2: (CONSTRUCTION ACTIVITY) - DISTURBANCE AREA = 9.84 AC.

- STRIP AND STOCKPILE TOPSOIL. INSTALL SILT FENCE AROUND PERIMETER OF TOPSOIL PILE AND SEED WITH TEMPORARY SEEDING MIX.
- COMMENCE MASS GRADING OPERATIONS. INSTALL ADDITIONAL EROSION CONTROL MEASURES INCLUDING STONE CHECK DAMS, WEAPERS TO BE MAINTAINED BY THE CONTRACTOR UNTIL GROUND COVER HAS BEEN ESTABLISHED AND REMOVAL IS APPROVED BY THE TOWN OF PENFIELD. CONTRACTOR TO SEED AND MULCH DISTURBED AREAS WITHIN 7 DAYS OF COMPLETION.
- SEED AND MULCH ALL DISTURBED AREAS WITHIN 7 DAYS IF NOT WORKED WITHIN 7 DAYS, AS REQUIRED BY GP-0-20-001. SEED WITH A SEED MIX AS INDICATED, AND PROVIDE MULCH AS SPECIFIED IN THE NOTES.
- CONTRACTOR MAY INSTALL UTILITIES DURING GRADING OPERATIONS. IT IS THE CONTRACTOR'S RESPONSIBILITY TO STABILIZE THE SITE AND VERIFY GRADING ELEVATIONS PRIOR TO UTILITY CONSTRUCTION. ADDITIONAL EROSION CONTROL MEASURES, INCLUDING STONE CHECK DAMS.

STEP 3: (STABILIZATION & MONITORING)

- COMPLETE INSTALLATION OF UNDERGROUND UTILITIES.
- INSTALL SIDEWALKS, CURB AND PAVEMENT WITH EROSION CONTROL MEASURES AS NECESSARY TO MINIMIZE SILT DISTRIBUTION ON EXISTING AND CONSTRUCTED ROADWAYS.
- MAINTAIN PERIMETER SILT FENCE.
- DUST SHALL BE CONTROLLED DURING CONSTRUCTION BY THE CONTRACTOR TO MINIMIZE EFFECT ON THE ADJACENT PROPERTIES. THE CONTRACTOR SHALL BE RESPONSIBLE FOR KEEPING THE EXISTING ROADWAYS AND DRAINAGE CHANNELS FREE OF MUD, DIRT, AND DEBRIS. THE CONTRACTOR WILL CLEAN THESE AREAS AS NECESSARY OR AS REQUIRED BY THE TOWN OF PENFIELD.

GRAPHIC SCALE
1 inch = 40 ft.

LEGEND

- BOUNDARY LINE
- PROPOSED STONE GEMER, MANHOLE AND INLET
- EXISTING TIELINE
- EXISTING CONTOUR
- PROPOSED 50FT ELEVATION
- PROPOSED FINISHED GRADE
- PROPOSED SILT FENCE

LEGEND

- BOUNDARY LINE
- PROPOSED STONE GEMER, MANHOLE AND INLET
- EXISTING TIELINE
- EXISTING CONTOUR
- PROPOSED 50FT ELEVATION
- PROPOSED FINISHED GRADE
- PROPOSED SILT FENCE

Project Title: FIVE MILE LINE ROAD ROTHFUSS PARK TOWN OF PENFIELD, MONROE COUNTY

Drawing Title: MULTI-PURPOSE SPORT FIELDS SITE, UTILITY & GRADING PLAN

Drawn By: MTO
Checked By: MRV
Scale: 1" = 40'
Date: 01/05/21

Town of Penfield
3100 ATLANTIC AVENUE, PENFIELD, NY

Legend

- BOUNDARY LINE
- PROPOSED STONE GEMER, MANHOLE AND INLET
- EXISTING TIELINE
- EXISTING CONTOUR
- PROPOSED 50FT ELEVATION
- PROPOSED FINISHED GRADE
- PROPOSED SILT FENCE

Legend

- BOUNDARY LINE
- PROPOSED STONE GEMER, MANHOLE AND INLET
- EXISTING TIELINE
- EXISTING CONTOUR
- PROPOSED 50FT ELEVATION
- PROPOSED FINISHED GRADE
- PROPOSED SILT FENCE

Legend

- BOUNDARY LINE
- PROPOSED STONE GEMER, MANHOLE AND INLET
- EXISTING TIELINE
- EXISTING CONTOUR
- PROPOSED 50FT ELEVATION
- PROPOSED FINISHED GRADE
- PROPOSED SILT FENCE

TOWN OF PENFIELD
STANDARD DETAIL #34

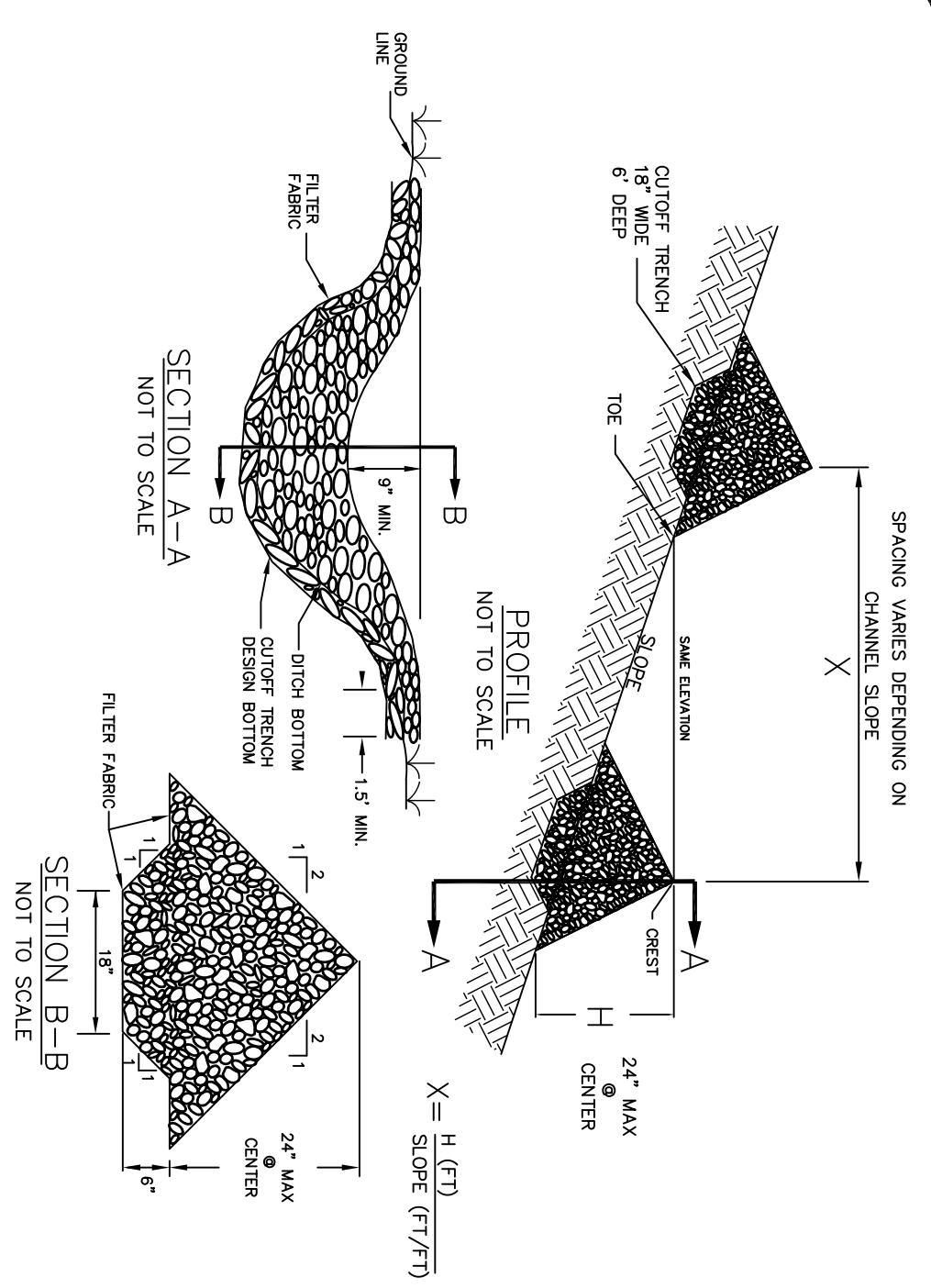

- CONSTRUCTION SPECIFICATIONS**
- 1) STONE WILL BE PLACED ON A FILTER FABRIC FOUNDATION TO THE LINES.
 - 2) SET UP CONSTRUCTION CHECK DAMS IN THE PLAN.
 - 3) EXTEND THE STONE A MINIMUM OF 1.5 FEET BEYOND THE DITCH BANKS TO UPSTREAM DAM.
 - 4) PREVENT CUTTING AROUND THE DAM.
 - 5) CHECK DAMS ARE NOT SUBJECT TO DAMAGE OR BLOCKAGE FROM DISPLACED STONES.

MAXIMUM DRAINAGE AREA - 2 ACRES

CHECK DAM DETAIL
(N.T.S.)

REVISED: 2019

TOWN OF PENFIELD
STANDARD DETAIL #35

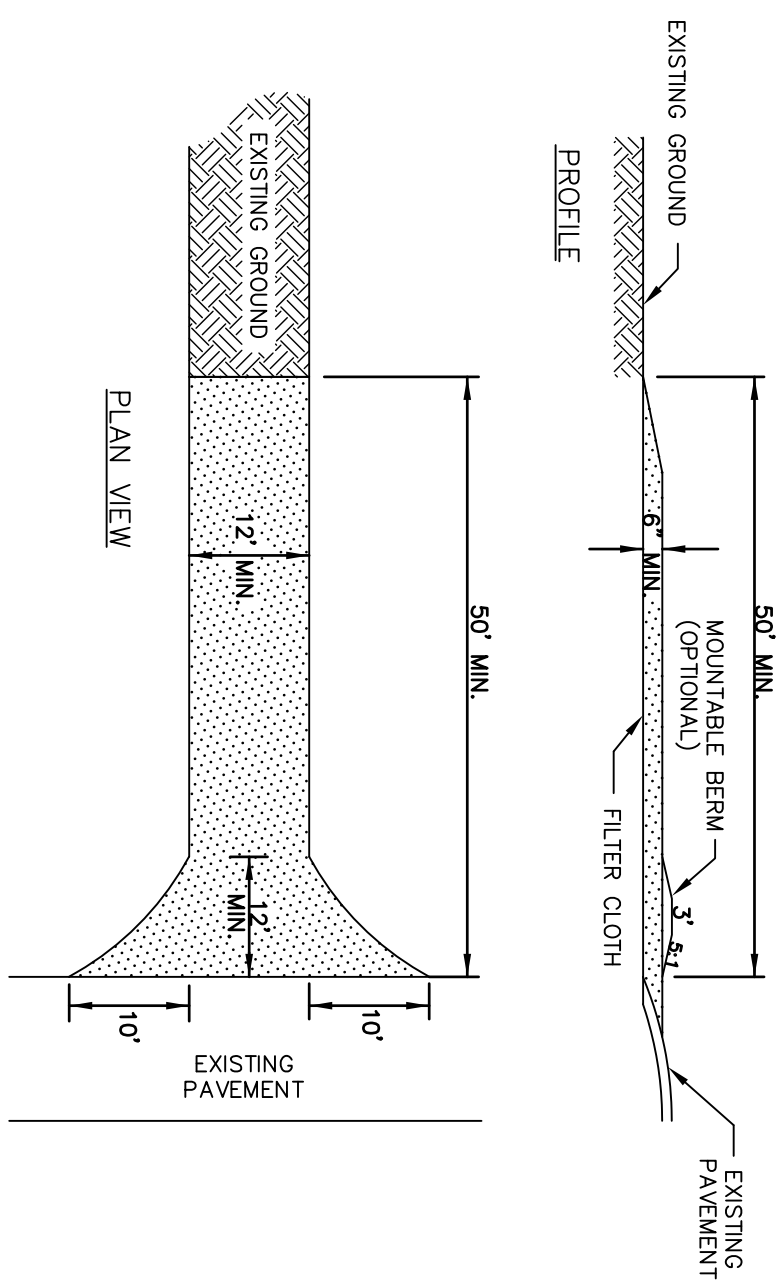

- CONSTRUCTION SPECIFICATIONS**
1. STONE SIZE - USE 1-4 INCH STONE OR RECLAIMED OR RECYCLED CONCRETE EQUIVALENT -
 2. LENGTH - AS REQUIRED, BUT NOT LESS THAN 50 FEET (EXCEPT ON A SINGLE RESIDENCE LOT WHERE A 30 FOOT MINIMUM LENGTH WOULD APPLY).
 3. THICKNESS - NOT LESS THAN SIX (6) INCHES.
 4. WIDTH - MINIMUM OF 12 FEET MINIMUM, BUT NOT LESS THAN THE FULL WIDTH AT POINTS WHERE INGRESS OR EGRESS OCCURS. MINIMUM FLOOR (24) FOOT IF SINGLE ENTRANCE TO SITE.
 5. GEOTEXTILE - WILL BE PLACED OVER THE ENTIRE AREA PRIOR TO PLACING OF STONE.
 6. SURFACE WATER - ALL SURFACE WATER FLOWING OR DIVERTED TOWARD CONSTRUCTION ENTRANCES SHALL BE PIPED BENEATH THE ENTRANCE. IF PIPING IS IMPRACTICAL, A MOUNTAINABLE BERM WITH 5:1 SLOPES WILL BE PERMITTED.
 7. MAINTENANCE - THE ENTRANCE SHALL BE MAINTAINED IN A CONDITION WHICH WILL PREVENT TRACKING OR FLOWING OF SEDIMENT ONTO PUBLIC RIGHT-OF-WAY. THIS MAY REQUIRE PERIODIC TOP DRESSING WITH ADDITIONAL STONE AS CONDITIONS DEMAND. SEDIMENT SHALL BE REMOVED IMMEDIATELY.
 8. WASHING - WHEELS SHALL BE CLEANED TO REMOVE SEDIMENT PRIOR TO ENTRANCE ONTO PUBLIC RIGHT-OF-WAY. WHEN WASHING IS REQUIRED, IT SHALL BE DONE ON TRAPPING DEVICE.
 9. PERIODIC INSPECTION AND NEEDED MAINTENANCE SHALL BE PROVIDED AFTER EACH RAIN.

STABILIZED CONSTRUCTION ENTRANCE
(N.T.S.)

REVISED: 2019

TOWN OF PENFIELD
STANDARD DETAIL #12

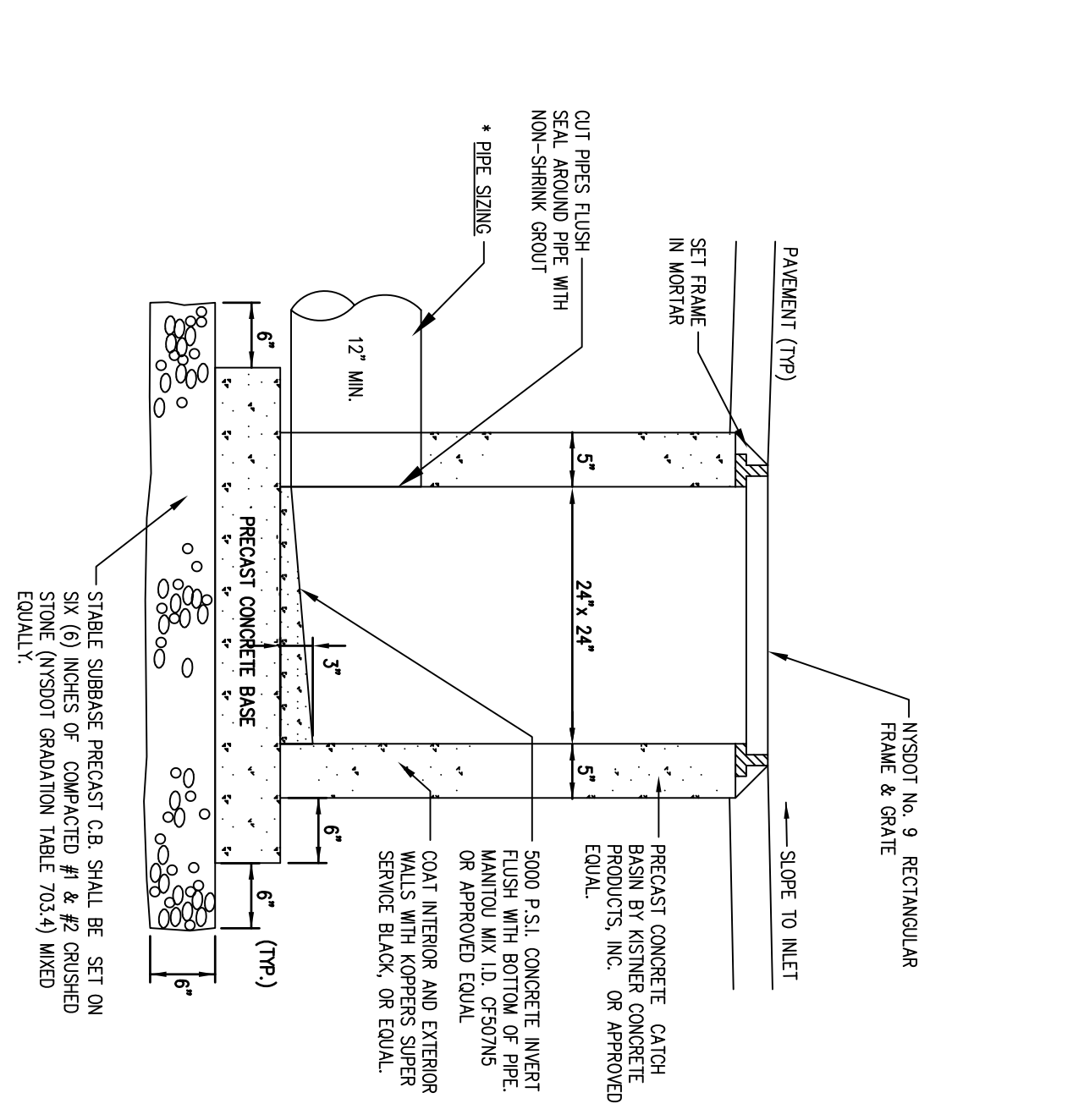

FIELD INLET DETAIL
(N.T.S.)

REVISED: 2019

TOWN OF PENFIELD
STANDARD DETAIL #32

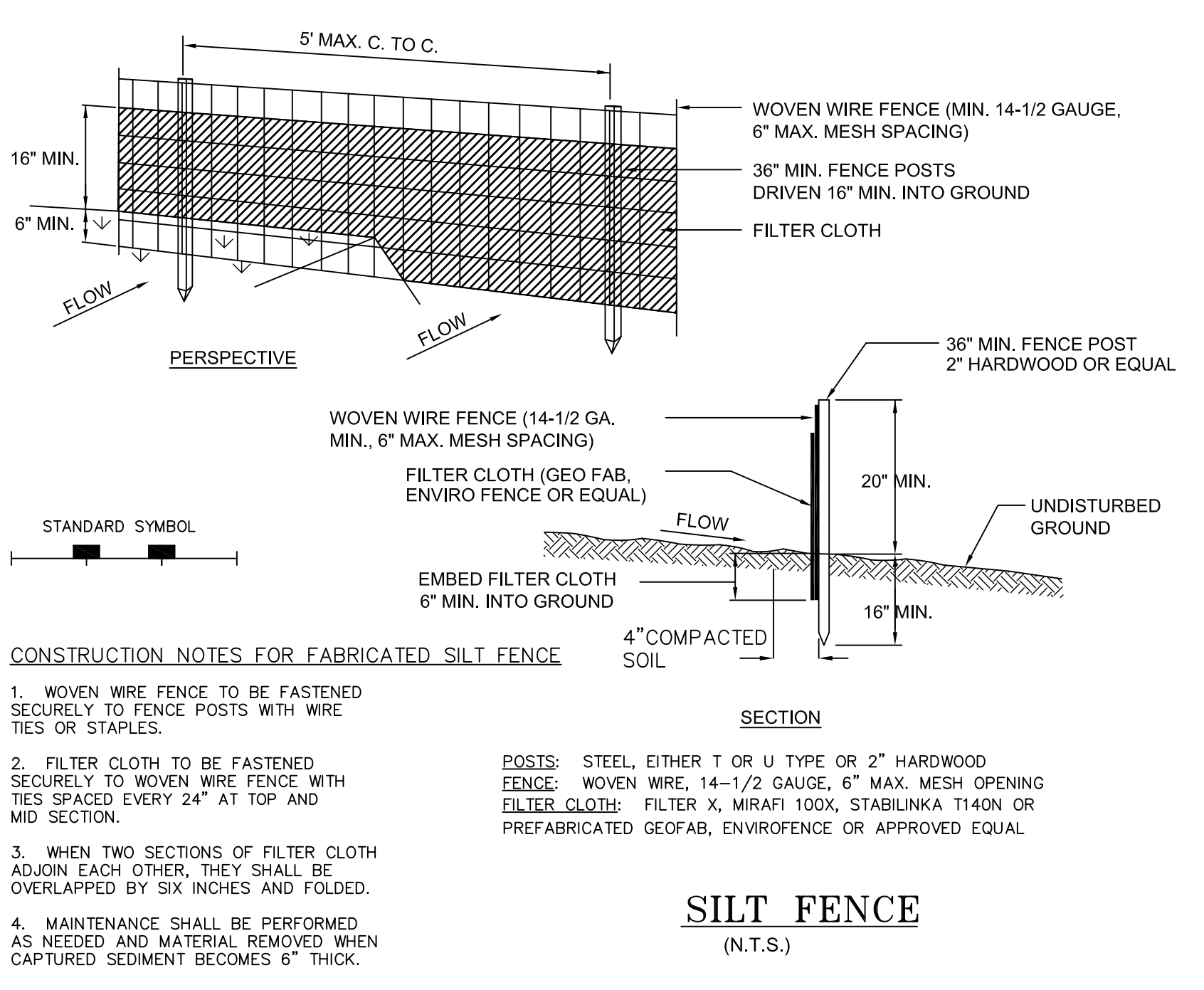

- CONSTRUCTION NOTES FOR FABRICATED SILT FENCE**
1. WOVEN WIRE FENCE TO BE FASTENED SECURELY TO FENCE POSTS WITH WIRE TIES OR STAPLES.
 2. FILTER CLOTH TO BE FASTENED SECURELY TO WOVEN WIRE FENCE WITH TIES SPACED EVERY 24" AT TOP AND MID SECTION.
 3. WHEN TWO SECTIONS OF FILTER CLOTH ADJOIN EACH OTHER, THEY SHALL BE OVERLAPPED BY SIX INCHES AND FOLDED.
 4. MAINTENANCE SHALL BE PERFORMED AS NEEDED AND MATERIAL REMOVED WHEN CAPTURED SEDIMENT BECOMES 6" THICK.

POSTS: STEEL, EITHER T OR U TYPE OR 2" HARDWOOD
FENCE: WOVEN WIRE, 14-1/2 GAUGE, 6" MAX. MESH OPENING
FILTER CLOTH: FILTER X, MIRAFI 100X, STABILINKA T140N OR PREFABRICATED GEOFAB, ENVIROFENCE OR APPROVED EQUAL

SILT FENCE
(N.T.S.)

REVISED: 2019

TOWN OF PENFIELD
STANDARD DETAIL

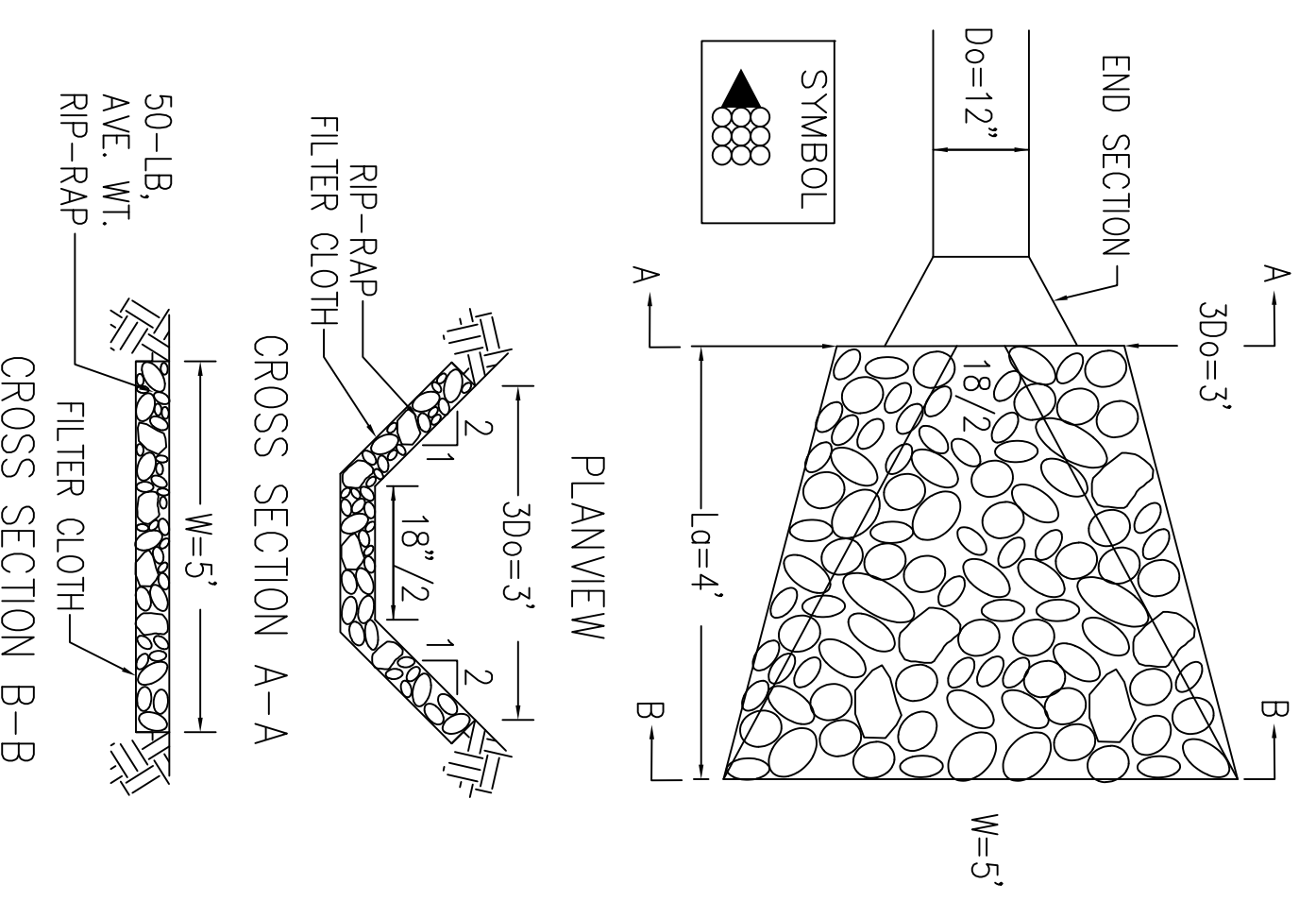

RIP-RAP OUTLET PROTECTION DETAIL
(N.T.S.)

REVISED: 2019

TOWN OF PENFIELD
STANDARD DETAIL

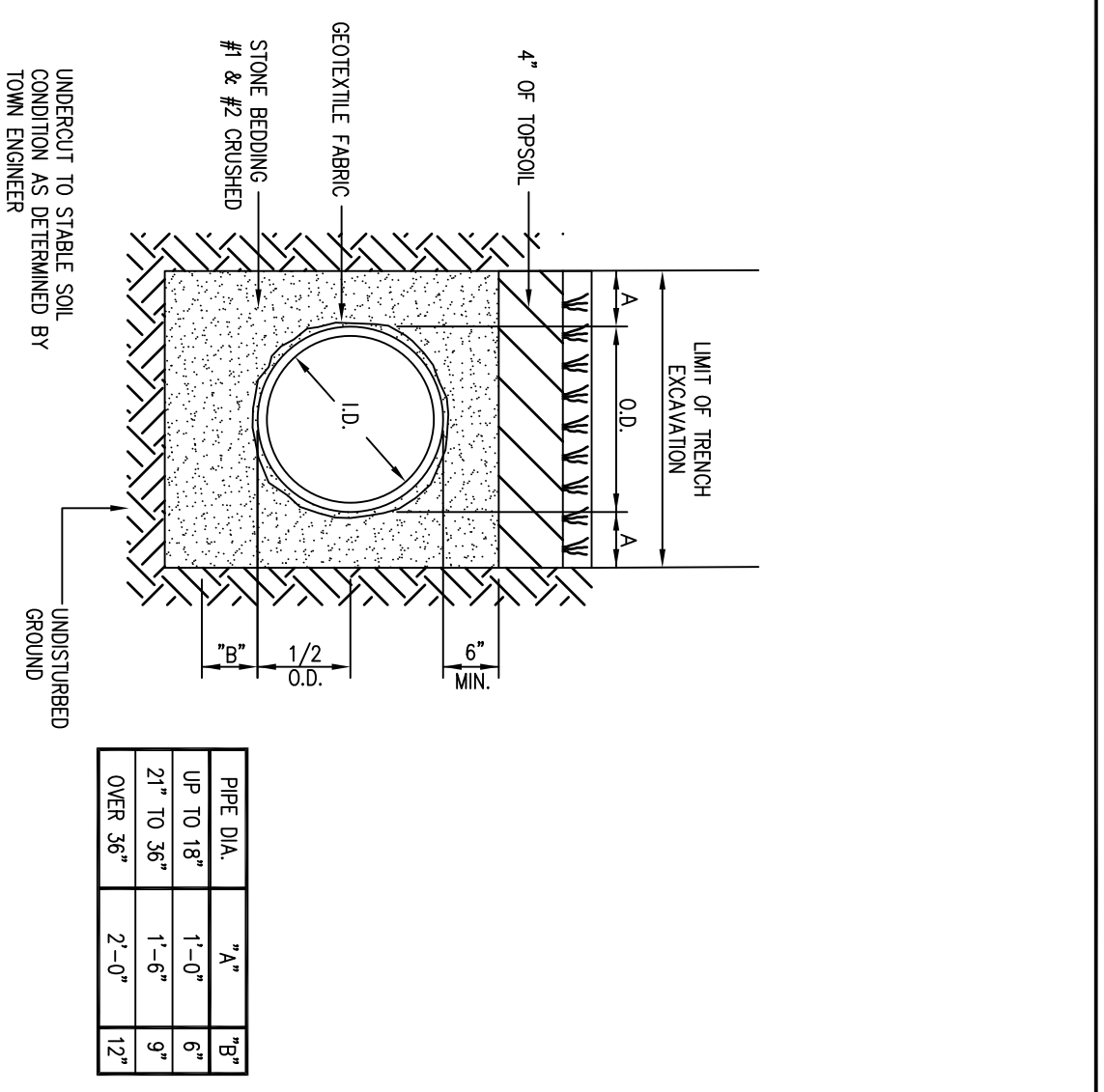

PERFORATED STORM SEWER
BEDDING DETAIL
(N.T.S.)

REVISED: 2019



ROTHFUSS PARK

Project Title:	FIVE MILE LINE ROAD ROTHFUSS PARK TOWN OF PENFIELD, MONROE COUNTY	Drawn By:	MTO
Drawing Title:	MULTI-PURPOSE SPORT FIELDS DETAIL SHEET	Checked By:	MRV
		Scale:	1" = N.T.S.
		Date:	01/05/21

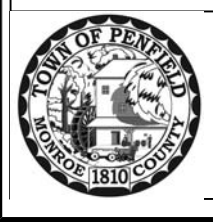

ADDENDUM #1 5/12/2021

TOWN OF PENFIELD

2021 ROTHFUSS PARK SPORTS FIELD PROJECT BID SHEET

ITEM #1 GRADING & EROSION CONTROL – Installation (base bid)

Price to grade/ shape three (3) multi-purpose sports fields including all associated new storm sewer, erosion control measures and lawn restoration with screened topsoil and seed per the attached specifications, including all labor, material, equipment:

	#	Unit	Unit Price	Total
A) Mobilization (Maximum 5% of total base bid)	1	LS	x \$	LS = \$
B) Maintenance and Protection of Traffic (Maximum 5% of total base bid)	1	LS	x \$	LS = \$
C) 12" Perf. CPP Storm Sewer Pipe, 0' to 12' depth	990	LF	x \$	LF = \$
D) 24" X 24" Precast Reinf. Concrete Field Inlet, Complete	4	EA	x \$	EA = \$
E) 12" Galvanized End Section Complete	1	EA	x \$	EA = \$
F) Excavation and Grading, with Compaction	+/-10,000	CY	x \$	CY = \$
G) Strip and Stockpile Topsoil	+/-10,600	CY	x \$	CY = \$
H) Clear and Grub Complete	1	LS	x \$	LS = \$
I) Sift and Process Topsoil Complete	1	LS	x \$	LS = \$
J) Install & Maintain Silt Fence, Inc. Removal Complete	1,256	LF	x \$	LF = \$
K) Install & Maintain Stone Check Dams, Inc. Removal Complete	1	EA	x \$	EA = \$
L) 50LB Average Weight Rip Rap	5	SY	x \$	SY = \$
M) Permanent Seeding of Area Inc. Replacement of Screened Topsoil from Onsite Sources, Hydroseed with mulch and Tackifer, Complete	9.8	AC	x \$	AC = \$
N) Install & Maintain Orange Construction Fence, Inc. Removal Complete	1,300	LF	x \$	LF = \$
O) Install & Maintain Inlet Protection, Inc. Removal Complete	4	EA	x \$	EA = \$
P) Existing Path Restoration (if needed)	1	LS	x \$	LS = \$

BID TOTAL _____

I have received, read and agree to the terms and conditions as set forth in the specifications. I hereby recognize and agree that upon execution of this document by an authorized officer of the Town of Penfield, that this document, together with the Contractor's bid/proposal as accepted by the Town of Penfield and all other documents prepared by or on behalf of the Town of Penfield for this solicitation, shall become the binding contract between the parties for the services to be provide in accordance with the terms and conditions set forth herein.

Firm Name _____ Signed By _____
Address _____ Printed Name _____
_____ Title _____
Federal ID # _____ Phone Number _____

Bid Acceptance and Contract Award

Upon award of the Penfield Town Board per resolution # _____ and by these signatures, the parties agree to all the terms, conditions and provisions of the bid proposal. The above Contractor's bid is accepted, except as noted, and the contract is awarded

Date: _____

By: _____
R. Anthony LaFountain, Supervisor